



# Manual

## MicroTron Series SW

Chemical Metering Pump

### *Installation Maintenance Repair Manual*



Max Flow Rate            17 GPD  
Operating Pressure       250 PSI

Sidewinder Pumps, Inc.  
P.O. Box 80769  
Lafayette, LA 70598-0769 USA  
Phone: 337-235-9838  
Fax: 337-235-9852  
[www.sidewinderpumps.com](http://www.sidewinderpumps.com)



09/08/2017

\*\*This document replaces all documents prior to this date.\*\*

# Table of Contents

I.	Introduction .....	3
	Model Numbering .....	3
II.	Unpacking .....	4
III.	Safety Considerations.....	4
	A. Chemical Compatibility .....	4
	B. Safety Equipment and Preparation .....	4
IV.	Installation.....	4
	A. Location .....	4
	B. Electrical.....	4
V.	Start-Up .....	5
	A. Priming the Pump .....	5
	B. Adjusting Feed Rate .....	5
	C. Stroke Length.....	5
	D. Calculating Output .....	5
	E. Optional Features .....	5
VI.	Maintenance .....	6
	A. Diaphragm Replacement .....	6
	B. Suction and Discharge Check Valve Replacement.....	7
	C. Liquid End Diagram .....	8
	D. Pump Replacement Parts .....	9
VII.	Trouble Shooting Guide .....	10

## Manufacturer’s Product Warranty

Sidewinder Pumps, Inc. warrants units of its manufacture to be free of defects in material or workmanship. Liability under this policy extends for 24 months from date of installation. Liability is limited to repair or replacement of any failed equipment or part proven defective in material or workmanship upon manufacturer’s examination. Removal and installation costs are not included under this warranty. Manufacturer’s liability shall never exceed the selling price of equipment or part in question. Sidewinder Pumps, Inc. disclaims all liability for damage caused by its products by improper installation, maintenance, use or attempts to operate products beyond their intended functionality, intentionally or otherwise, or any unauthorized repair. Sidewinder Pumps, Inc. is not responsible for damages, injuries or expense incurred through the use of its products.

The above warranty is in lieu of other warranties, either expressed or implied. No agent of ours is authorized to provide any warranty other than the above.

## 30 Day Billing Memo Policy

Sidewinder Pumps, Inc. maintains a unique factory exchange program to ensure uninterrupted service with minimum downtime. If your unit malfunctions, call 337-235-9838, and provide our technician with Model and Serial Number information. If we are unable to diagnose and solve your problem over the phone, a fully warranted replacement unit will be shipped, usually within 48 hours, on a 30 Day Billing Memo.

This service requires a purchase order and the replacement unit is billed to your regular account for payment. The replacement unit will be billed at current list price for that model less any applicable resale discount. Upon return of your old unit, credit will be issued to your account if the unit is in warranty. If the unit is out of warranty or the damage not covered, a partial credit will be applied based upon a prorated replacement price schedule dependent on the age of the unit. Any exchange covers only the controller or pump. Electrodes, liquid end components and other external accessories are not covered.



# I. Introduction

This manual covers all facets of operation of the Sidewinder MicroTron™ pump, including unpacking, mounting, electrical and plumbing connection, and start-up. Safety, maintenance and repair, warranty, and factory information is also provided. Please read this manual completely before proceeding. Observe safety protocols and heed all warnings and precautions.

## Model Numbering

MicroTron™ Series SW pump model numbers define the output, pressure and control functions present on a particular pump. Your pump may be supplied with one or more of the options described in this manual. To determine what features apply to your pump, check the model number label located on the pump.

### Standard Model Number Example

**SW 2 17 X 1 – B F S P**

**Pressure Rating** \_\_\_\_\_

**2** = 250 psi at 17 gallons per day

**Gallon Per Day Rating** \_\_\_\_\_

**Control Options** \_\_\_\_\_

**X** = Stroke Length Adjust

**Voltage** \_\_\_\_\_

**1** = 120 volt - 50/60 Hz - .35A with USA plug  
**2** = 240 volt - 50/60 Hz - .65A no plug (optional)

**Pump Head Material** \_\_\_\_\_

**K** = Kynar with Ceramic check balls (optional)  
**B** = T-Style 316SS with check valves (standard)

**Seat Material** \_\_\_\_\_

**V** = Viton (optional)  
**F** = Teflon (standard)

**Check Ball** \_\_\_\_\_

**C** = Ceramic standard with Kynar head / optional with 316SS head  
**S** = 316SS standard with 316SS head / optional with Kynar head

**Tubing Connections** \_\_\_\_\_

**P** = 1/4" MNPT

**NOTE:** This list represents our most popular options. **If you have an option not covered, contact the factory or your dealer for more details.**



## II. Unpacking

The MicroTron™ pump has been shipped as a complete package, ready for installation. If the shipping carton shows any signs of damage, notify the shipping company immediately upon receipt. Sidewinder Pumps, Inc. cannot be held responsible for damage from shipping.

Unpack the carton and insure the following items are present:

1. Metering pump
2. Instructional manual

## III. Safety Considerations

**NOTE:** All MicroTron™ pumps are primed with water before leaving the factory. If the solution to be pumped is not compatible with water, disassemble the pump fluid end before use. After disassembly, thoroughly dry the pump head, valves, and seals before pump is reassembled and used.

### A. Chemical Compatibility

MicroTron™ metering pumps are designed to work with most liquid chemicals depending upon your pump's liquid end materials of construction. A chemical resistance chart is available for determining specific compatibility with a wide variety of chemicals.

### B. Safety and Preparation

Always wear the proper protective clothing and gear when working around chemicals and chemical metering pumps. Safety glasses, gloves, and aprons are critical in preventing accidental exposure to dangerous chemicals. Liquids under pressure can present a special hazard when a line or seal is punctured resulting in the spraying of chemical many yards away. If a chemical spillage occurs, consult the Material Safety Data Sheet (MSDS) for specific instructions regarding the chemical being used.

## IV. Installation

### A. Location

Select a mounting location convenient to the chemical supply as well as a source of power for the pump. Do not install the pump in a location where the ambient temperature exceeds 120 degrees F (50°C). Higher temperatures will affect the output as well as the useful life of the pump. While the MicroTron™ pump is suitable for most outdoor installations, do not use the standard poly tubing in direct sunlight. If you must mount pump in direct sunlight or under bright fluorescent lights use ultra-violet resistant tubing, consult your distributor or the factory. Accessory item R00225 (plastic mounting bracket) is recommend for a secure installation.

### B. Electrical

1. The **Standard** MicroTron™ pump has a voltage regulated internal power supply capable of operating in the range of approximately 95 to 135 VAC. Use a supply voltage of 100 to 120 VAC for best results. The 3-wire grounded plug must be used in a 3-wire wall plug.
2. With a 240 volt option, the MicroTron™ pump has a voltage regulated internal power supply capable of operating in the range of approximately 195 to 260 VAC. Use a supply voltage of 210 to 250 VAC for best results.

## V. Start-Up

### A. Priming the pump

Plug in pump, set stroke to 100% and strokes per minute to maximum speed. While pump is operating, if fluid begins moving, no further priming is required. If fluid is not moving, open bleed valve where equipped, approximately one turn until fluid begins to move. When suction line fills, close bleed valve. Do not over tighten bleed valve. Damage may occur.

### B. Adjusting feed rate

The standard Model B allows for the exact setting of the pumps stroking rate (speed) on the pump's control panel. Standard strokes per minute settings available are: 1, 2, 3, 4, 5, 6, 7, 10, 15 and increase by 5 thereafter up to the maximum of 125 (B-155 models have a max speed of 160 strokes/minutes).

### C. Stroke length

The stroke length can be adjusted on all MicroTron™ pumps. This adjustment is a mechanical adjustment made using the large knob on the control panel. To avoid damage to the pump, this adjustment should only be made while the pump is running at a high stroking rate.

### D. Calculating Output

A pump's output per minute can be determined by dividing the maximum rated gallons per day by 1440 (minutes per day). For example, a 30 gallons per day (gpd) pump at a maximum stroke length and speed setting of 125 strokes per minute (spm) will pump 0.000167 gallons per stroke (gps).

$$30 \div 1440 = 0.0208 \text{ gpm} \div 125 \text{ spm} = 0.000167$$

With this value and the pump's speed setting (strokes per minute) you can calculate your pump's output at it's rated pressure. A 30 gpd pump set at 50 strokes per minute:

$$50 \text{ spm} \times 0.000167 \text{ gps} \times 1440 \text{ (minutes per day)} = 12.02 \text{ gallons per day}$$

Reducing the stroke length will reduce the pump's output again. If the example pump above had it's stroke length reduced to 50% the 12.02 gallons per day output is reduced to 6.01. (example: 12.02 gpd x 0.50 = 6.01 gpd)

A higher product viscosity will reduce the output. Pressures lower than the pump's rating can increase the output.

### E. Optional Features

A pump's output per minute can be determined by dividing the maximum rated gallons per day by 1440 (minutes per day). For example, a 30 gallons per day (gpd) pump at a maximum stroke length and speed setting of 125 strokes per minute (spm) will pump 0.000167 gallons

#### 1. External Pacing

The external pacing option allows the speed of the pump to be controlled by an external device like a flow meter that gives dry contact switch closures. The pump sends out a 5 volt

D.C. current to read a switch closure. Each time the pump sees the switch closure it strokes once, up to its maximum strokes per minute rate.

### **2. Hall Effect Meter Pacing**

This option is like the external pacing only the pump divides the incoming switch closures by 9 before stroking on time. This is a three wire connection: D.C. voltage, signal and ground.

### **3. External Stop**

Pumps with this option are allowed to stroke as long as they see a closed condition from a dry contact source like a flow switch or drum level wand. When an open condition is seen the pump is not allowed to stroke.

## **VI. Maintenance**

The Sidewinder MicroTron™ pump is designed for long service life with minimum maintenance. If for any reason, maintenance is necessary or desirable, the MicroTron™ pump is easily maintained.

Before any maintenance or service is performed, observe the following precautions:

1. Disconnect the MicroTron™ pump from power source.
2. Drain chemical from discharge tubing.
3. Disconnect discharge tubing from pump.
4. If the MicroTron™ pump is used in a flooded suction application, remove foot valve from chemical container.
5. Observe relevant safety protocols when handling parts which have been in contact with hazardous chemicals.

### **A. Diaphragm Replacement**

1. Remove fluid end cover by lightly prying it loose from the fluid end.
2. Remove the four screws attaching the fluid end to pump body.
3. Remove the fluid end from the pump body.
4. Unscrew the diaphragm from the pump shaft in a counter-clockwise direction. Be careful that diaphragm support ring does not fall out.
5. Do not allow sharp or abrasive objects to come in contact with pump parts.
6. Inspect end of shaft to assure that threads are in good condition. Replace shaft bellows if necessary. No further disassembly is recommended.
7. Screw new diaphragm onto pump shaft until it bottoms out on shoulder of shaft. It is not necessary to tighten further.
8. Replace fluid end. Make sure that screws are evenly tightened.
9. Reconnect plumbing and power. Prime the pump.

## **B. Suction and Discharge Check Valve Replacement for Plastic (Kynar)**

1. Disconnect suction tubing from pump.
2. Unscrew fitting from pump head.
3. Remove check valve from suction fitting and replace.
4. Remove O-ring from cavity in fluid end.
5. Remove check valve from suction side pump and replace.
6. Install new O-ring in cavity of fluid end.
7. Replace valve fitting with check valve in fluid end.
8. Replace fluid end. Make sure that screws are evenly tightened.
9. Reconnect plumbing and power. Prime the pump.

- NOTES:**
1. **Tighten pump head screws after pump's initial week of operation.**
  2. **When installing check valves, remember that the seats are always installed at the bottom.**



### C. Liquid End Diagram - Kynar shown

*\*Item may not appear exactly as shown.*

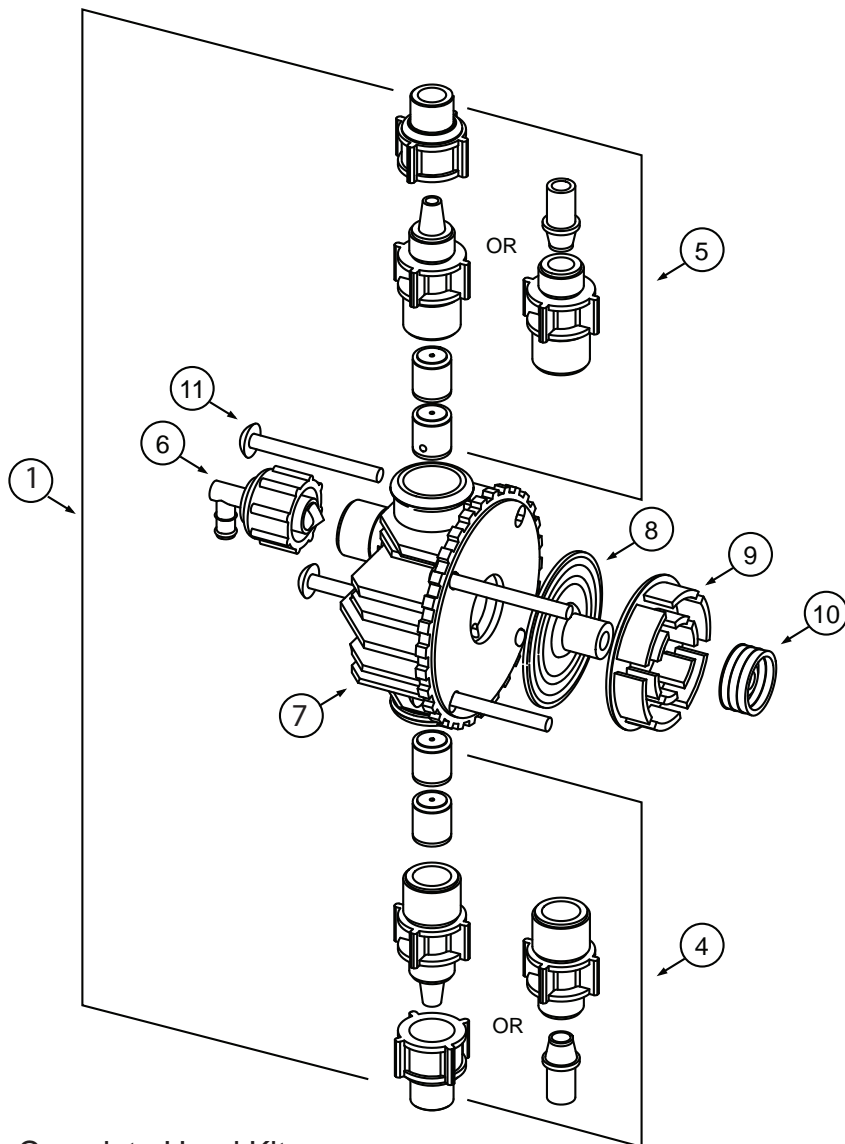

Item	Description
1	Complete Head Kit
4	Suction Valve-MNPT
5	Discharge Valve-MNPT
6	Bleed Valve Assembly
7	Pump Head
8	Pump Diaphragm
9	Support Ring
10	Shaft Seal
11	Head Bolts

Complete Head Kit  
includes items:  
4,5,6,7,8, and 11



## D. Replacement Parts

Getting the right materials of construction for your spare parts is easy. Using positions 7-10 of the pump model number, example: O130X1-**KFCP** for plastic or O130X1-**BFSP** for 316SS. Find the assembly needed and add the codes of your pump's liquid end after the standard prefix part number for the assembly.

### Part Assemblies

Item	Description	Part Number
1.....	Complete Head Assembly .....	CKR-2- _ _ _ _
4.....	Suction Valve Assembly.....	SUC- _ _ _ _
5.....	Discharge Valve Assembly.....	DIS- _ _ _ _
6.....	Priming Valve Assembly .....	PRI- _ _ _ _

<u>Body</u>	<u>Seat</u>	<u>Ball</u>	<u>Connection</u>
K- Kynar	V- Viton	C- Ceramic	P- 1/4" MNPT
S- 316 Stainless	F- Teflon	S- Stainless	

### Single Parts

7.....	Pump Head 150 & 250 psi.....	R00039- _
8.....	Diaphragm 150 & 250 psi .....	R00006
9.....	Support Ring 150 & 250psi.....	R00068
10.....	Shaft Seal.....	R00050
11.....	Head Bolts.....	R00045

## VII. Trouble Shooting

PROBLEM	CAUSE	REMEDY
Pump does not achieve or maintain prime	Air trapped in suction line	Straighten suction line so as to eliminate high spots.
	Foot valve contaminated or improperly installed	Inspect foot valve screen and assure that foot valve is in a vertical position below fluid level.
	Excessive lift	Maximum suction lift is 5 feet with water or fluids of similar specific gravity; less with heavier liquids such as acids. Mount pump in a lower position relative to the chemical container.
	Suction fittings not properly tightened	Check fittings. Overtightening may cause restriction. Conversely, if <b>any</b> leakage occurs, pump will suck air and fail to prime.
	Worn or contaminated check valves	Inspect check valves in fluid end for cleanliness. Clean or replace as necessary.
	Split or pinch in suction tube	Inspect suction tube through its full length to assure that there are no splits at the connections or other restrictions. Move any objects or equipment which impinges upon suction tube or reroute as required to assure a smooth transition from foot valve to pump.
	Low chemical level	Check fluid level in chemical supply tank.
Insufficient fluid	Stroke adjustment set too low	Check operation of stroke limiter knob. If pump delivers too low adjustable rate, check settings. Readjust as required.
	Worn or contaminated check valves	Inspect, clean or replace as necessary.
	Obstruction in suction line	Check suction line for obstructions, clogging, kinks or pinch points.
	Clogged foot valve screen	Clean or replace foot valve screen.
	Output (system) pressure too high	Relocate the injector to a lower pressure part of the the system.
	Diaphragm worn or torn	Replace diaphragm, making sure that it is screwed on fully to shoulder of shaft.
	Electronic failure	Consult dealer or factory.

Excessive fluid	Failure or lack of antisiphon valve	Inspect or add anti-siphon valve. This is caused when system is in a vacuum condition or valve in delivery applications with flooded suction which feeds systems at very low pressures.
	Excessive stroke rate	Lower the stroke rate if adjustable on your pump.
	Improper stroke length	Reduce stroke length.
Pump will not pump	System pressure too high	Check system pressure to assure that it is within system rated parameters of the pressure.
	Diaphragm improperly installed	Make sure that diaphragm is screwed fully onto shaft.
	Check valves worn or clogged	Clean or replace as required.
Pump will not run not plugged in	Pump not turned on or not plugged in	Check outlet with meter to assure that correct or voltage is present and that power supply cord is in good condition and plugged in.
	Electronic failure	Consult dealer or factory.
Excessive noise	Pump not primed	Prime pump.
	No output pressure	Add an anti-siphon valve to provide 25 PSI restriction on pump discharge.

# Pneumatic:



## 42/62/82 Series

Grease Lubricated  
Plunger Pumping

Flows to 275 QPD  
Pressure to 10,000 PSI

TM



## 40/60/80 Series

Grease Lubricated  
Plunger Pumping

Flows to 360 QPD  
Pressure to 3,500 PSI

TM



## 164 Series

Flows to 680 QPD  
Pressure to 2,400 PSI



## 164CR Series

Flows to 935 QPD  
Pressure to 2,400 PSI



## Walking Beam Pump

WB4 -1/4" diameter plunger  
WB8 -1/2" diameter plunger



## 44/64/84 Series

Flows to 120 QPD  
Pressure to 10,000 PSI

## Specialty:



## 42/62/82 E Series Pump

Micrometer Stroke Adjuster  
feature with graduated scales  
for precise flow control.

Flows to 275 QPD  
Pressure to 10,000 PSI  
Available in 1/4", 3/8", & 1/2"  
diameter plungers

TM

## 42/62/82 Gas Recovery Series Pump

Available in 1/4", 3/8" & 1/2"  
diameter plungers.  
Contact factory for  
pump sizing



Chemical Metering Pumps  
[www.sidewinderpumps.com](http://www.sidewinderpumps.com)

## AC Powered Chemical Pump



08/04/17  
\*\*This document replaces any and all documents prior to this date.\*\*



Chemical Metering Pumps  
[www.sidewinderpumps.com](http://www.sidewinderpumps.com)

## DC Powered Chemical Pump



08/04/17  
\*\*This document replaces any & all documents prior to this date.\*\*







## Chemical Metering Pumps

[www.sidewinderpumps.com](http://www.sidewinderpumps.com)

*“Dedicated to providing state of the art metering solutions for all your chemical treatment needs.”*

### Sidewinder Pumps, Inc.

**Pneumatic Chemical Metering Pumps**

**Solar Powered Chemical Metering Pumps**

**Electric Powered Chemical Metering Pumps**

[www.sidewinderpumps.com](http://www.sidewinderpumps.com)

[info@sidewinderpumps.com](mailto:info@sidewinderpumps.com)

337-235-9838

